

# PD4-N59/N60-IP

Plug & Drive High-Pole DC Servo Motor IP65 - NEMA 23/24



## OPTIONS



## SOFTWARE



## TECHNICAL DATA

<b>Operating Voltage</b>	12-48 VDC
<b>Max. phase current</b>	Adjustable via software up to 4.8 A (1% increments), 100% = 3.2 A
<b>Interface</b>	RS485 or CANopen
<b>Operating type</b>	RS485 interface: position, speed, reference run, flag position, clock-direction, analog and joystick, analog position, torque CANopen interface: profile position, speed, reference run, interpolated position, torque
<b>Operating mode</b>	1/1, 1/2, 1/4, 1/5, 1/8, 1/10, 1/16, 1/32, 1/64, adaptive (1/128)
<b>Step frequency</b>	0 to 50 kHz in clock-direction mode, 0 to 25 kHz in all other modes
<b>Inputs</b>	6 opto-coupler inputs (5 - 24 V)
<b>Outputs</b>	Open drain (0 switching, max. 24 V/0.5 A)
<b>Position monitoring</b>	Automatic error correction up to 0.9°
<b>Current reduction</b>	Adjustable in 1% increments
<b>Protective circuit</b>	Overvoltage, undervoltage and temperature >80°C, integrated ballast switching
<b>Temperature range</b>	-10 to +40°C
<b>Connection type</b>	M12
<b>New functions</b>	Closed loop/sinusoidal commutation/dspDrive/programmable as a sequential controller using NanoJ Easy (RS485)

## ORDER IDENTIFIER

PD4-N5918X4204-IP-  
2 = RS485 Interface  
3 = CANopen Interface

## ACCESSORIES

Z-K4700/50 Charging Capacitor  
ZK-RS485-USB Converter  
ZIB-PDx-N Additional Board

## CAUTION

We recommend using a back-up capacitor of sufficient size to stabilize the operating voltage.

# PD4-N59/N60-IP

Plug & Drive High-Pole DC Servo Motor IP65 - NEMA 23/24



## VERSIONS

Type	Holding Torque Ncm	Weight kg	Length „A“ mm
PD4-N5918X4204-IP	53.7	0.49	66.5
PD4-N5918M4204-IP	113	0.8	80.6
PD4-N5918L4204-IP	198	1.22	101.6
PD4-N6018L4204-IP	354	1.48	112

## DIMENSIONS (IN MM)

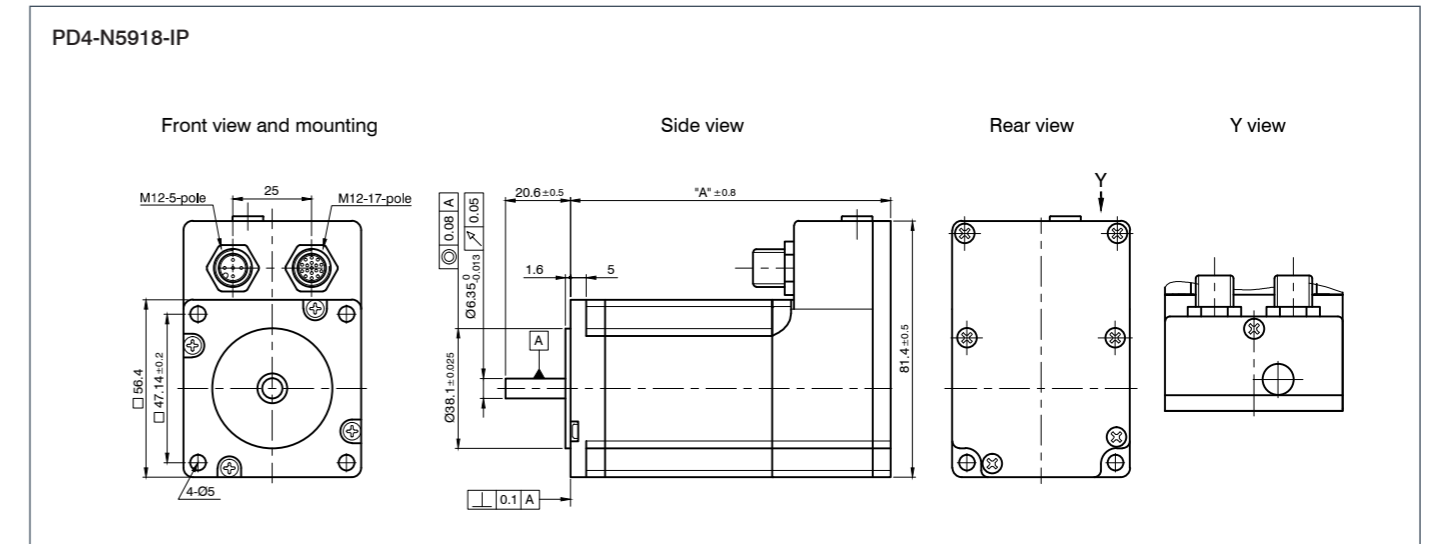

## DIMENSIONS (IN MM)

